

0.8mm Pitch



Connectors

HDR series

Interface Connectors

Outline

HDR series connectors are very small surface mount (SMT) interface connectors with their contacts arranged at a pitch of 0.8 mm, designed for the purpose of saving extra space on printed circuit boards.

Features

- Long-life design allowing up to 5,000 mating cycles
- Low profile with overall height of 5mm from the PCB surface
- Sequential structure allowing up to two stacked connections
- One-touch-lock-type and detachable / re-attachable housing
- EMI/ESD-shielded and over-molded type metal housing
- IDC type connector on the cable end allows simultaneous termination

Principal Applications

Portable information terminals, smaller-sized office automation equipment, and their peripherals

Electrical Characteristics

Rated voltage	125V AC (r.m.s.)
Rated current	0.5 A
Insulation resistance	Over 1000 megohms at 250V DC
Dielectric withstanding voltage	350V AC (r.m.s.)
Contact resistance	70 milliohms or less

Document Disclaimer

- When placing orders with us, minimum order quantities are set for every product.
- Be sure to contact us before starting preliminary design of PCBs using our connectors.
- The specifications and information shown in the catalog are subject to change without notice.

Reflow temperature profile (for reference purposes)

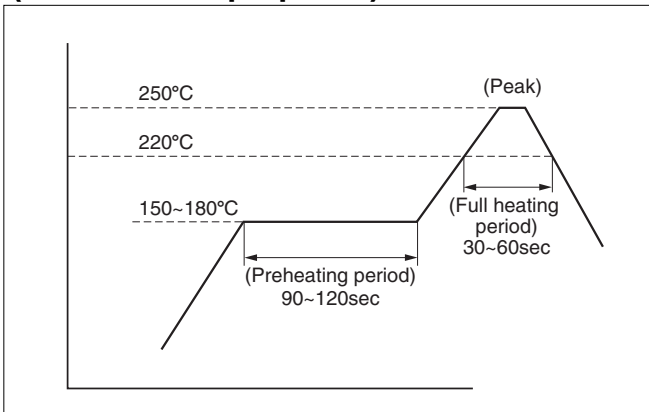

The reflow temperature profile shown in this drawing is for reference purposes. This profile depends on requirements such as reflow equipment, soldering paste, and PCB size. Thus, this profile may not meet with your specific situation. Please evaluate your PCB-mounting soldering and set your own reflow temperature profile.

●Applicable products

HDR-EA()LMYPG1-()(+)

HDR-EA()LFYPG1-()(+)

Flow temperature profile (for reference purposes)

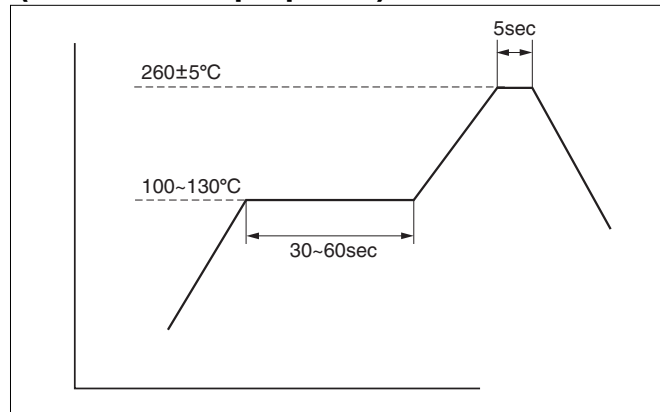

The flow temperature profile as shown above is for reference purposes. This profile depends on requirements such as the PCB size. Thus, this profile may not meet with your specific situation. Please evaluate your PCB-mounting soldering and set your own flow temperature profile.

●Applicable products

HDR-EC()FDT()(-)(+)

HDR-EC()LFDT()(-)(+)

Product List



IDC type male connector for cable
HDR-E()MAG1+

A-6
HDR series...4



Soldering type male connector for cable
HDR-E()MSG1+

A-7
HDR series...5

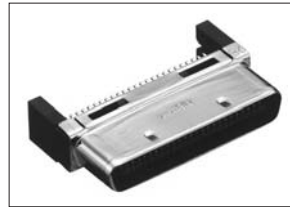

Straddle SMT type male connector for PCB
HDR-E50MT()+

A-8
HDR series...6



Right-angle SMT type male connector for PCB
HDR-EA()LMYPG1-()()+

A-9
HDR series...7



IDC type female connector for cable
HDR-E()FAG1+

A-10
HDR series...8



Right-angle SMT type female connector for PCB
HDR-EA()LFYPG1-()()+

A-11
HDR series...9



Straight through hole type female connector for PCB
HDR-EC()FDT()-()+

A-12
HDR series...10

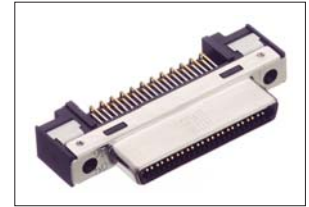

Right-angle through hole type female connector for PCB
HDR-EC()LFDT()-()+

A-13
HDR series...11



EMI-filtered vertical plastic housing for standard and thin cable
HDR-E()LP()()-()

A-14
HDR series...12



EMI-filtered screw-lock vertical type plastic housing
HDR-E26LPH

A-15
HDR series...13

IDC type male connector for cable
HDR- E () MAG1+

For cable

IDC

EMI shielded

RoHS



● Configuration of product Part No.

HDR- E () MAG1+

- | | |
|---------------------------------|--------------------------------|
| ① Series name | ⑤ Compatible cable |
| ② E: With metal shell | A: AWG#30 (7/0.1), dia. 0.58mm |
| ③ No. of contacts: 14, 26 or 50 | ⑥ Contact plating |
| ④ Type of contact | G1: 0.76μm or more Gold plate |
| M: IDC type, Male | |

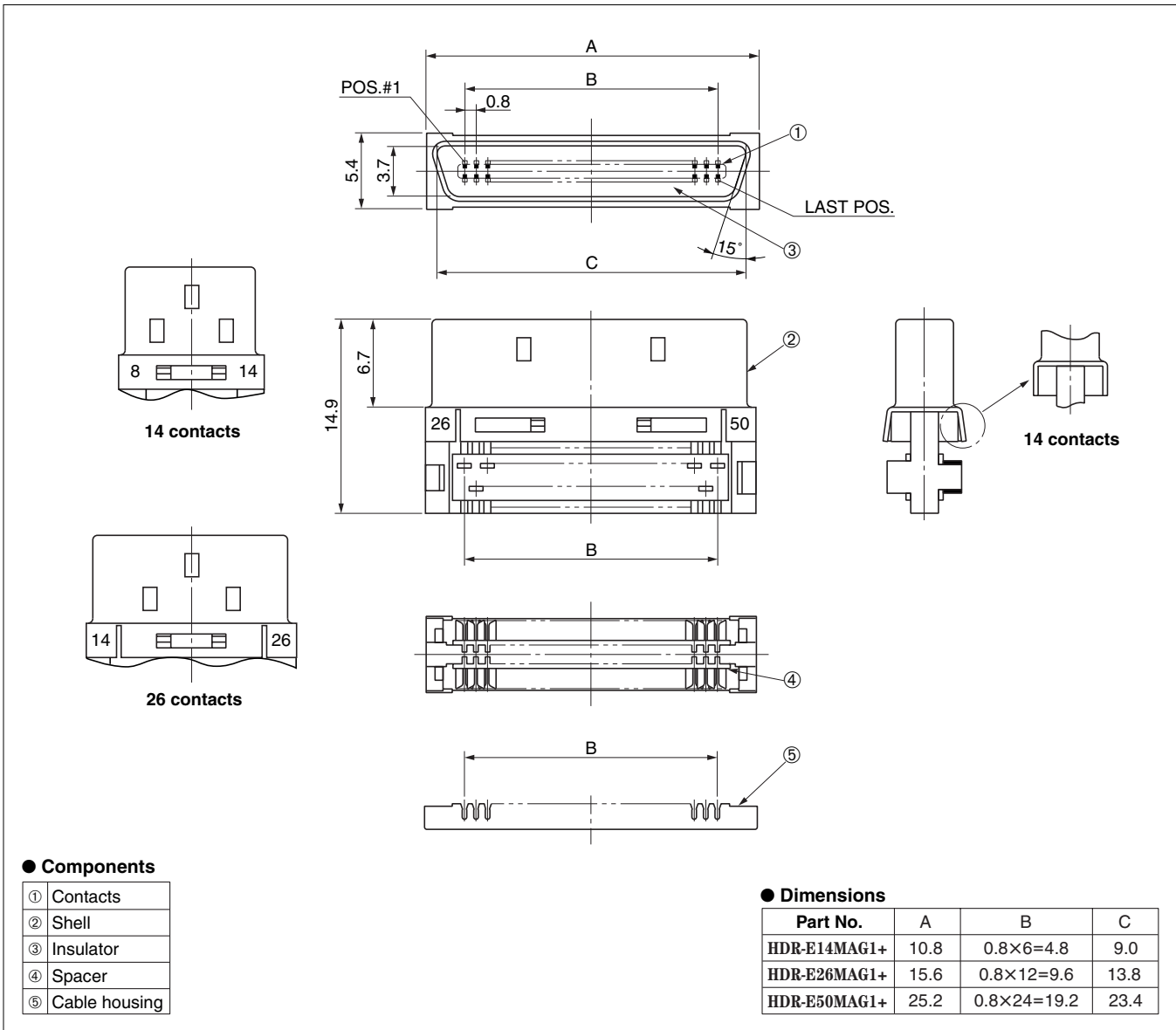

Mating connector: HDR series SMT type or through hole type female connector

For use with housings: HDR series upright housing

Required tools: Termination tool: FHAT-0029, IDC tool: FHPT-923B, Hand presser: MFC-K1 (Refer to page Tool-10)

Soldering type male connector for cable
HDR-E()MSG1+

For cable

Soldering

EMI shielded

RoHS



● Configuration of product Part No.

HDR- E () M S G1+

- ① Series name
 ② E: With metal shell
 ③ No. of contacts: 26 or 50
 ④ Male
 ⑤ Soldering
 ⑥ Contact plating
 G1: 0.76μm or more Gold plate

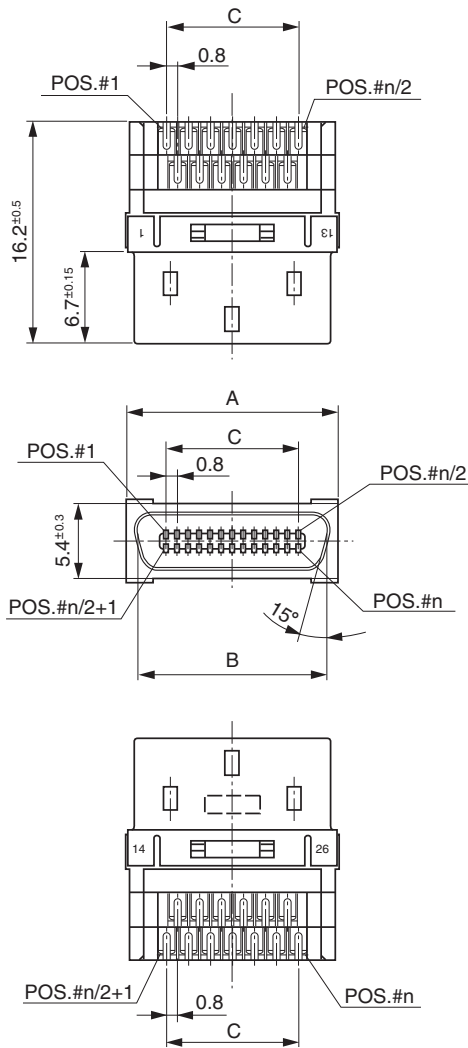

26-contact connector

● Dimensions

Part No.	A	B	C
HDR-E26MSG1+	15.6	13.8	0.8×12=9.6
HDR-E50MSG1+	25.2	23.4	0.8×24=19.2

Mating connector: HDR series female connector

For use with housings: HDR-E()LPH

Straddle SMT type male connector for PCB HDR-E50MT()+

For PCB

Straddle SMT

RoHS

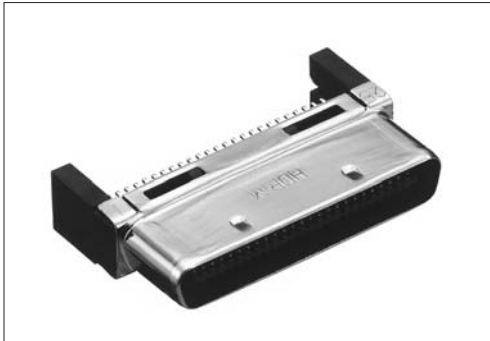

● Configuration of product Part No.

HDR- E 50 MT ()+

- ① Series name
- ② No. of contacts: 50
- ③ Type of contact
MT: Straddle SMT type, male
- ④ PCB thickness
Blank : 0.4 mm
A : 0.8 mm

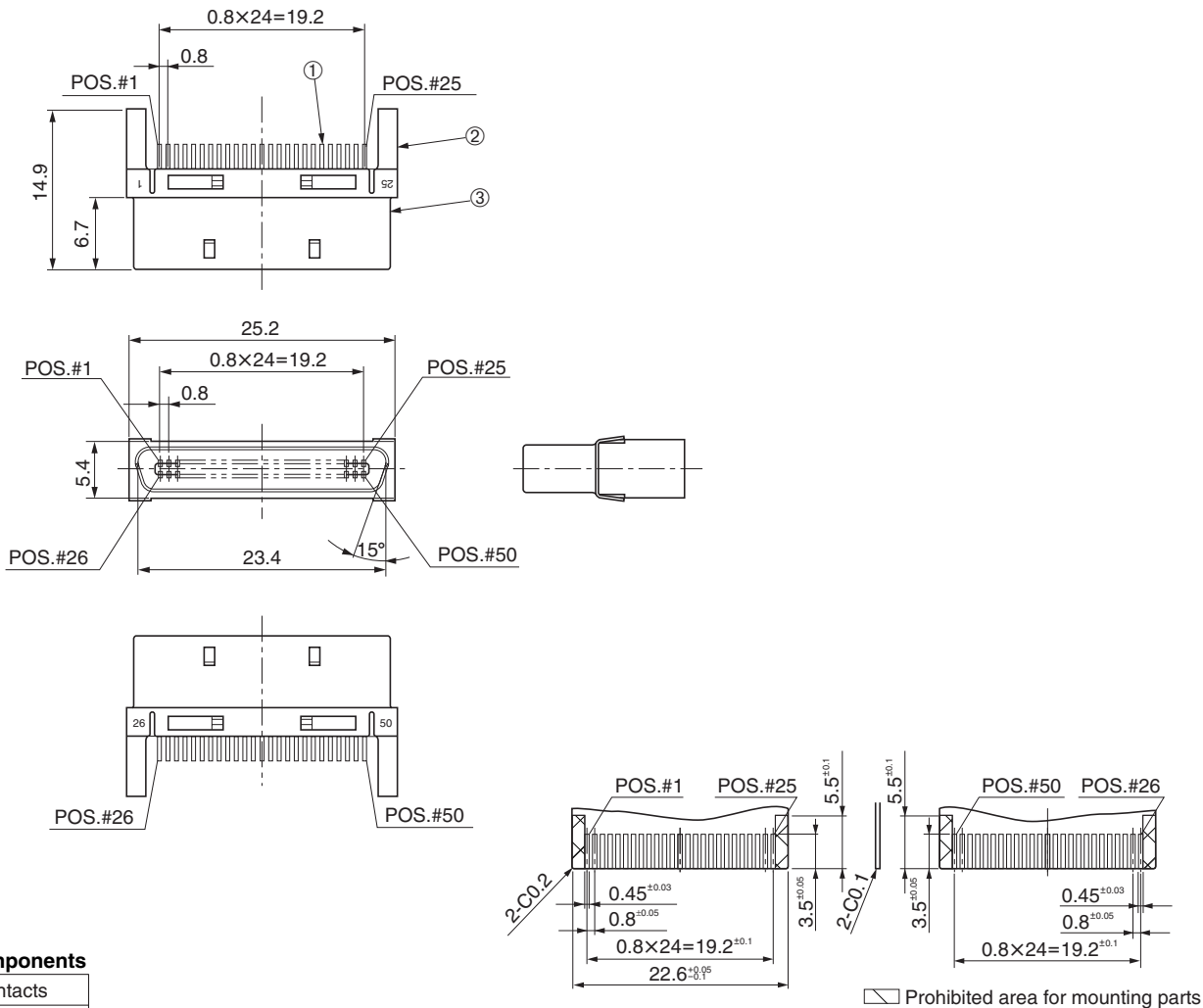

Recommended PCB layout

Mating connector: HDR series SMT type female connector

Right-angle SMT type male connector for PCB
HDR-EA()LMYPG1-()()+

For PCB

Right-angle SMT

RoHS



● Configuration of product Part No.

HDR-EA () LMY P G1- () ()+

- | | |
|---------------------------------|-----------------------------------|
| ① Series name | ⑥ Lock screw |
| ② Contact pitch: 0.635 mm | Blank : None |
| ③ No. of contacts: 14 or 26 | SL : Provided |
| ④ Type of contact | ⑦ Length of lock screw |
| LMY: Right-angle SMT type, male | E: 6.6 (standard) |
| ⑤ Contact plating | K: 3.3 (for HDR-E () LPA-LS) |
| G1: 0.76 μm or more Gold plate | Compatible with B-to-B and B-to-C |

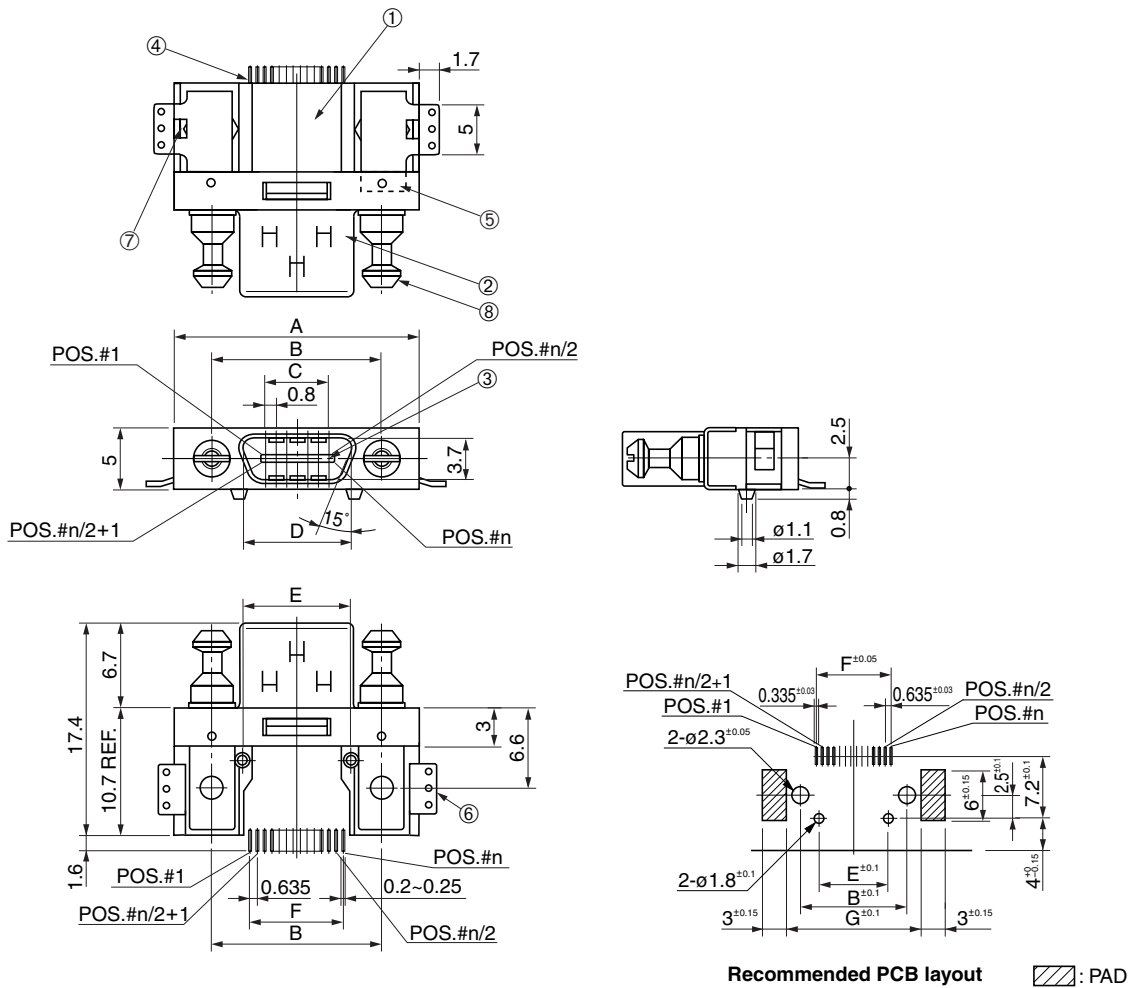

● Components

- | |
|---------------|
| ① Insulator A |
| ② Shell |
| ③ Contacts |
| ④ Insulator B |
| ⑤ Square nuts |
| ⑥ Hold down |
| ⑦ Hex nuts |
| ⑧ Lock screw |

● Dimensions

Part No.	A	B	C	D	E	F	G
HDR-EA14LMYPG1-()()+	20.0	14.4	4.8	9	9.2	8.255	19.0
HDR-EA26LMYPG1-()()+	24.8	19.2	9.6	13.8	14	15.875	23.8

Mating connector: HDR series IDC type or solder type female cable connector

For use with housing: -SLE: HDR series vertical housing

-SLK: HDR series vertical housing -LS, -LSA

IDC type female connector for cable
HDR-E()FAG1+

For cable

IDC

RoHS

EMI shielded



● Configuration of product Part No.

HDR-E () F A G1+

① ② ③ ④ ⑤ ⑥

- ① Series name
- ② E: With metal shell
- ③ No. of contacts: 14 or 26
- ④ Type of contact
F: IDC type, female

- ⑤ Compatible cable
A: AWG#30 (7/0.1), dia. 0.58 mm
- ⑥ Contact plating
G1: 0.76 μm or more Gold plate

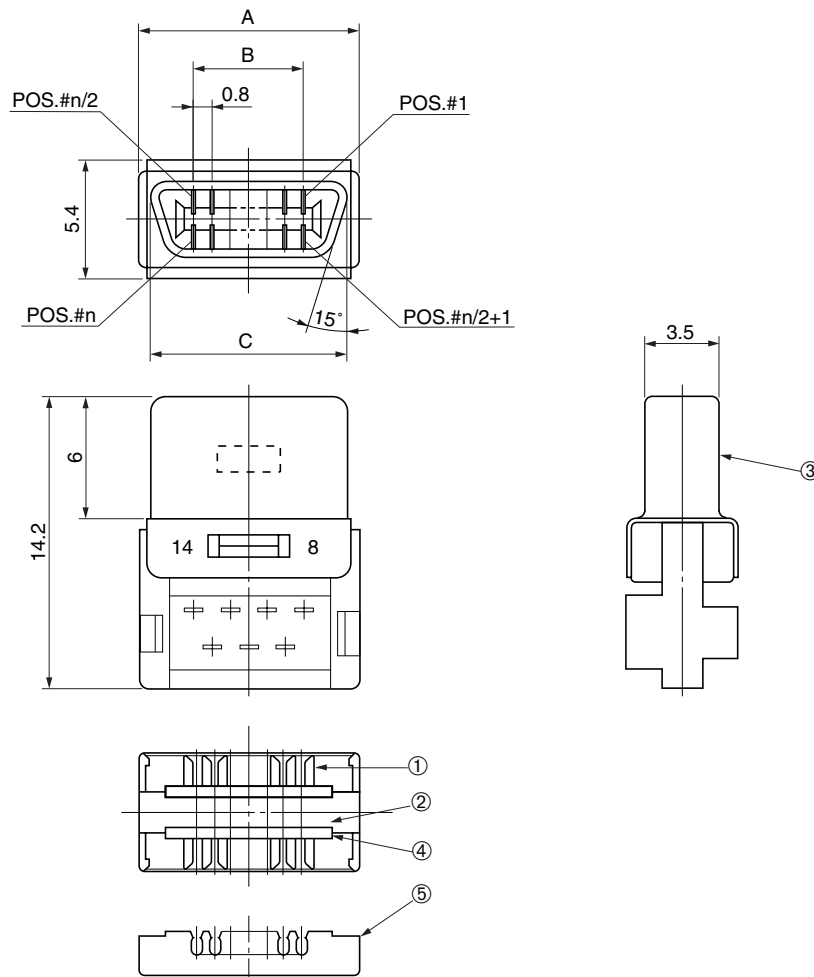

● Components

①	Contacts
②	Insulator
③	Shell
④	Spacer
⑤	Cable housing

● Dimensions

Part No.	A	B	C
HDR-E14FAG1+	10.8	4.8	8.8
HDR-E26FAG1+	15.6	9.6	13.6

Mating connector: HDR series SMT type male connector

For use with housings: HDR series vertical housing

Required tools: Termination tool: FHAT-0029, IDC tool: FHPT-923B, Hand presser: MFC-K1 (Refer to page Tool-10)

Right-angle SMT type female connector for PCB
HDR-EA()LFYPG1-()(+)

For PCB

Right-angle SMT

RoHS



● Configuration of product Part No.

HDR-EA () LFY P G1- () ()+

- | | |
|-----------------------------------|-----------------------------------|
| ① Series name | ⑥ Lock screw |
| ② Contact pitch: 0.635 mm | Blank: None |
| ③ No. of contacts: 14 or 26 | SL : Provided |
| ④ Type of contact | ⑦ Length of lock screw |
| LFY: Right-angle SMT type, female | E: 6.6 (standard) |
| ⑤ Contact plating | K: 3.3 (for HDR-E () LPA-LS) |
| G1: 0.76 μm or more Gold plate | Compatible with B-to-B and B-to-C |

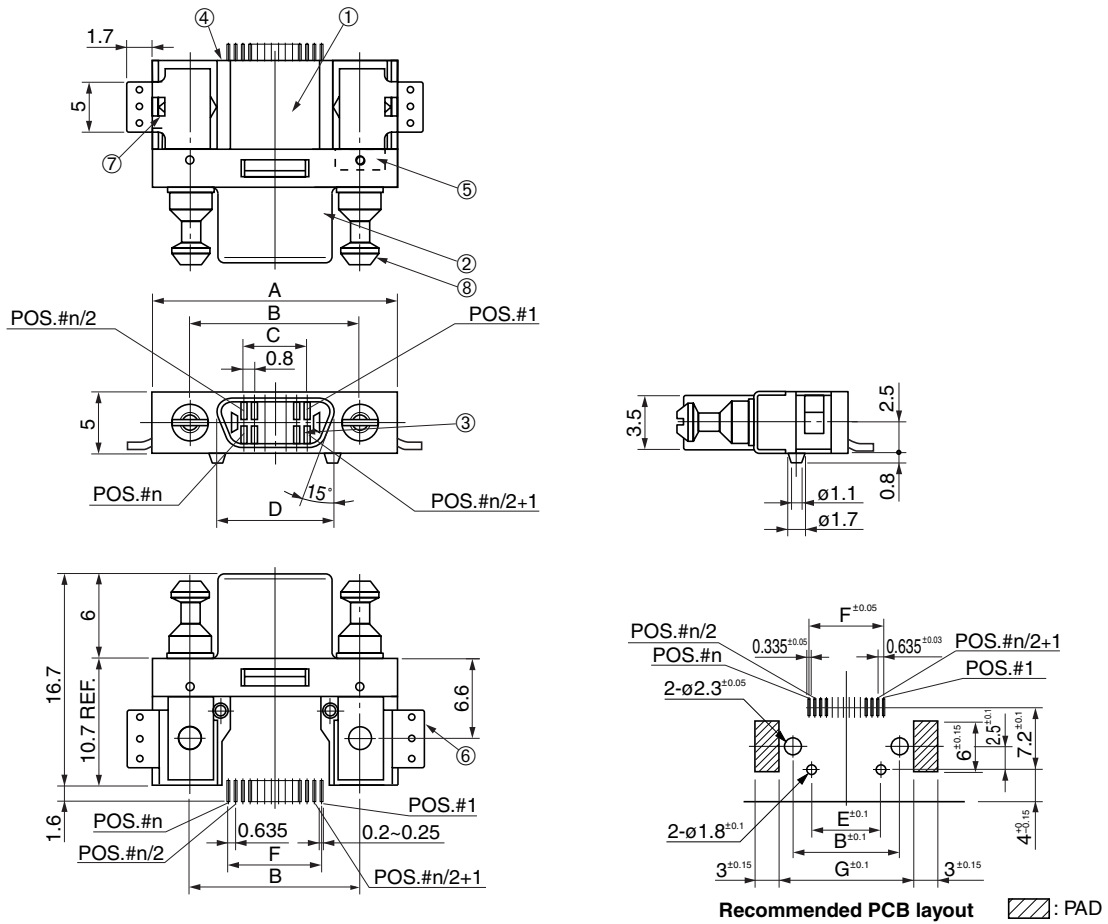

● Components

- | |
|---------------|
| ① Insulator A |
| ② Shell |
| ③ Contacts |
| ④ Insulator B |
| ⑤ Square nuts |
| ⑥ Hold down |
| ⑦ Hex nuts |
| ⑧ Lock screw |

● Dimensions

Part No.	A	B	C	D	E	F	G
HDR-EA14LFYPG1-()(+)	20.0	14.4	4.8	8.8	9.2	8.255	19.0
HDR-EA26LFYPG1-()(+)	24.8	19.2	9.6	13.6	14	15.875	23.8

Mating connector: HDR series IDC or solder type male cable connector

For use with housing: -SLE: HDR series vertical housing

-SLK: HDR series vertical housing -LS, -LSA

Straight through hole type female connector for PCB
HDR-EC()FDT()-()+

For PCB

Straight Through hole

RoHS

EMI shielded



● Configuration of product Part No.

HDR- EC () FDT ()- ()+

- ① Series name
- ② No. of contacts: 14 or 26
- ③ Type of contact
FD: Straight through hole type, female
- ④ With ground contact
- ⑤ Contact plating
G2: Min. 0.76 μm Gold plate
- ⑥ Lock screw
Blank: None
SL : Provided (Panel thickness: 1.12 mm)

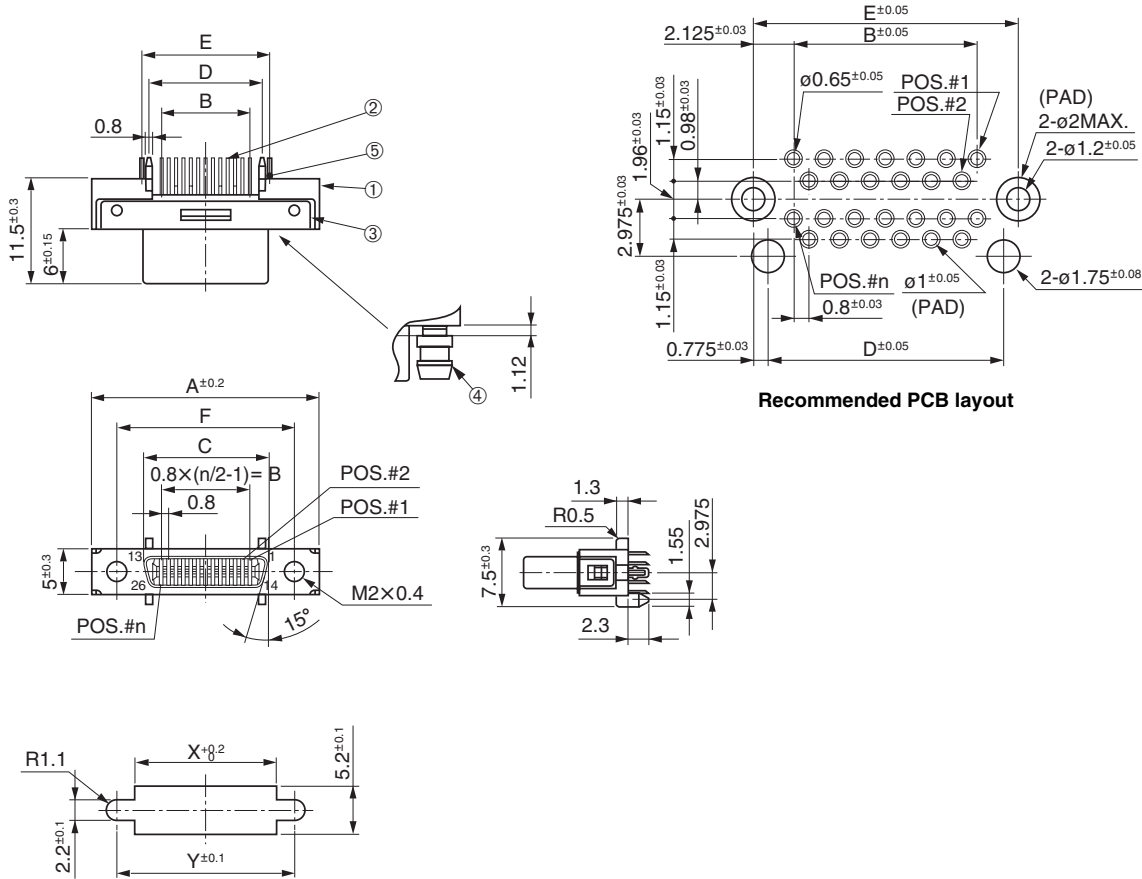

Recommended PCB layout

Recommended panel cut-out dimensions

● Components

①	Insulator
②	Contacts
③	Shell
④	Lock screws
⑤	Board lock pin

● Dimensions

Part No.	A	B	C	D	E	F
HDR-EC14FDT()-()+	20	0.8×6=4.8	8.8	7.5	9.05	19.2
HDR-EC26FDT()-()+	24.8	0.8×12=9.6	13.6	12.3	13.85	14.4

Mating connector: HDR series male connector

Right-angle through hole type female connector for PCB
 HDR-EC()LFD T()-()+

For PCB

Right-angle Through hole

RoHS

EMI shielded

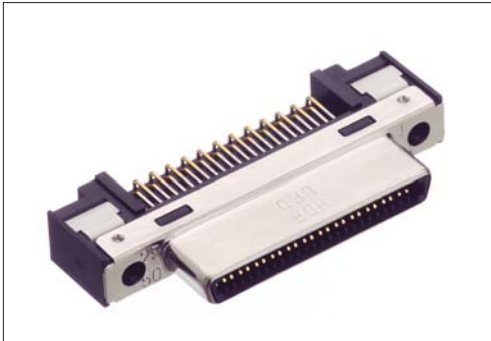

● Configuration of product Part No.

HDR- EC () LFD T () - () +

- | | |
|--|----------------------------|
| ① Series name | ⑥ Lock screw |
| ② No. of contacts: 14, 26 or 50 | Blank: None |
| ③ Type of contact | SLD : Screw lock |
| LFD: Right-angle through hole type, female | SLE : Spring lock |
| ④ With ground contact | SLG : Screw lock |
| ⑤ Through hole length, contact plating | (Panel thickness: 1.12 mm) |
| Blank : 1.65 mm, } Min. 0.1 μm Gold plate | |
| 1 : 2.08 mm, } + Min. 0.5 μm Palladium alloy | |
| G2 : 2.08 mm, Min. 0.76 μm Gold plate | |

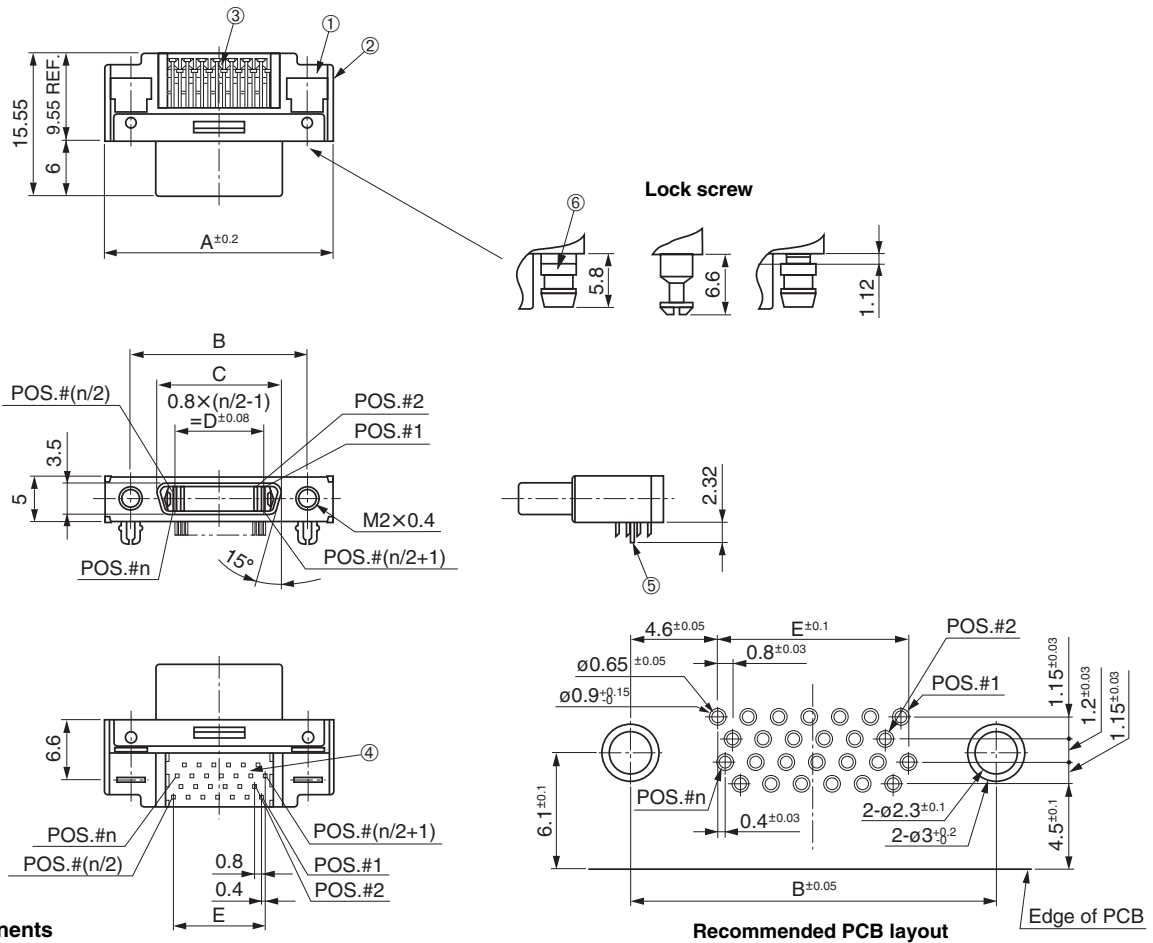

● Components

① Shell
② Insulator
③ Contacts
④ Bracket
⑤ Board lock
⑥ Lock screw

● Dimensions

Part No.	A	B	C	D	E
HDR-EC14LFD T()-()+	20	14.4	8.8	0.8×6=4.8	5.2
HDR-EC26LFD T()-()+	24.8	19.2	13.6	0.8×12=9.6	10
HDR-EC50LFD T()-()+	34.4	28.8	23.2	0.8×24=19.2	19.6

Mating connector: HDR series male connector

EMI-filtered vertical plastic housing for standard and thin cable
HDR-E()LP()()-()

Housing

Vertical

RoHS

EMI shielded



● Configuration of product Part No.

HDR-E () LP ()()-()

- | | |
|----------------------------------|---------------------------------|
| ① Series name | ⑤ Color of housing |
| ② No. of contacts 14, 26 or 50 | Blank: Gray |
| ③ Type of housing: Vertical type | 5 : Black |
| ④ Compatible cable | ⑥ Length of lock spring |
| A: Standard cable | Blank: PCB side lock screw -SLE |
| B: Thin cable | LS : PCB side lock screw -SLK |

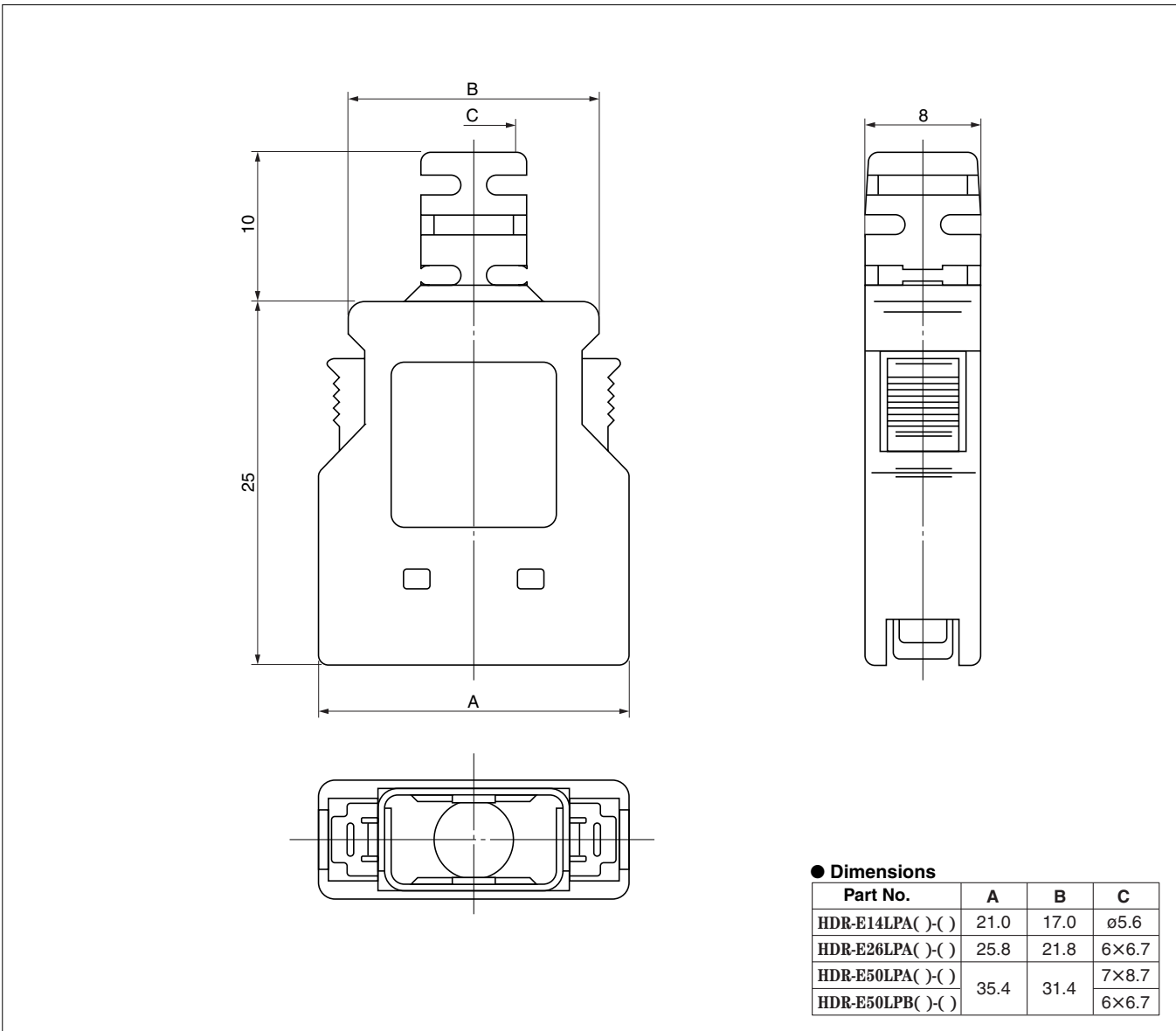

● Dimensions

Part No.	A	B	C
HDR-E14LPA()-()	21.0	17.0	ø5.6
HDR-E26LPA()-()	25.8	21.8	6×6.7
HDR-E50LPA()-()	35.4	31.4	7×8.7
HDR-E50LPB()-()			6×6.7

For use with connectors: HDR series IDC type cable connector HDR-E()MAG1+, HDR-E()FAG1+

Required tools: Clamp caulking tools: FHPT-0024A, for 14 contacts cable connectors (Refer to page Tool-10)

FHPT-0022A, for 26 contacts and 50 contacts thin cable connectors

FHPT-0023A, for 50 contacts thick (standard) cable connectors

EMI-filtered screw-lock vertical type plastic housing
HDR-E26LPH

Housing

Vertical

RoHS

EMI shielded



● Configuration of product Part No.

HDR- E 26 LP H

- ① Series name
- ② No. of contacts: 26
- ③ Type of housing
- ④ Serial number

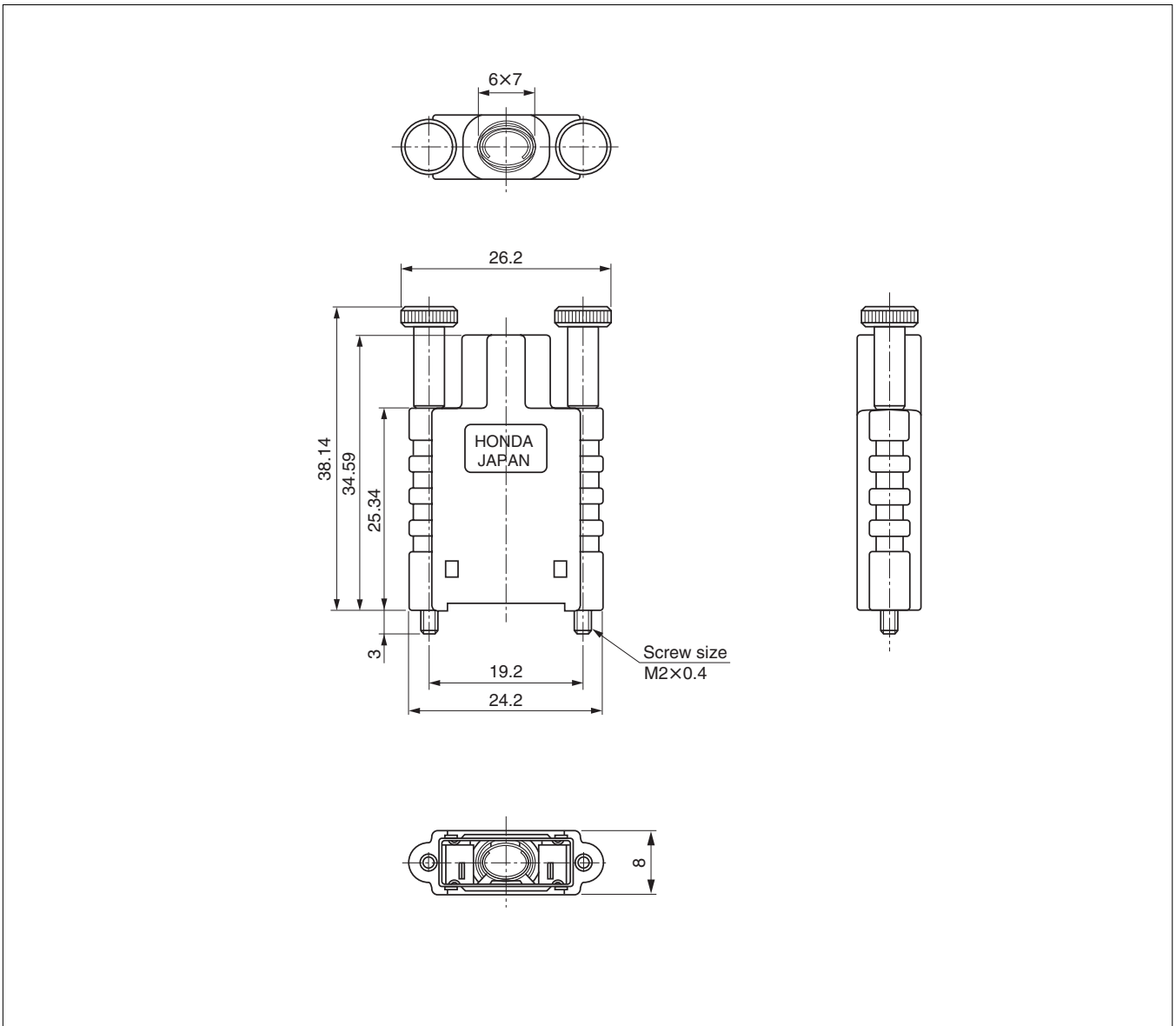

Mating connector: HDR series female connector

For use with connector: HDR-E26MAG1+, HDR-E26MSG1+

Required tools: Clamp caulking tools: FHPT-0022A (Refer to page Tool-10)

EMI-filtered vertical type plastic housing with mounting hardware for spring-lock, for heavy wires and relay connections
HDR-E26LPKA+

Housing

For Relay connections

EMI-filtered countermeasures

RoHS



● Configuration of product Part No.

HDR- E 26 LP K A+

① ② ③ ④ ⑤

- ① Series name
- ② No. of contacts: 26
- ③ Form of housing
Vertical type housing
- ④ Serial number
For use with cables: Outside diameter of heavy wire: 10.0-11.7 mm
- ⑤ Thickness of relay panel: 1.6 mm

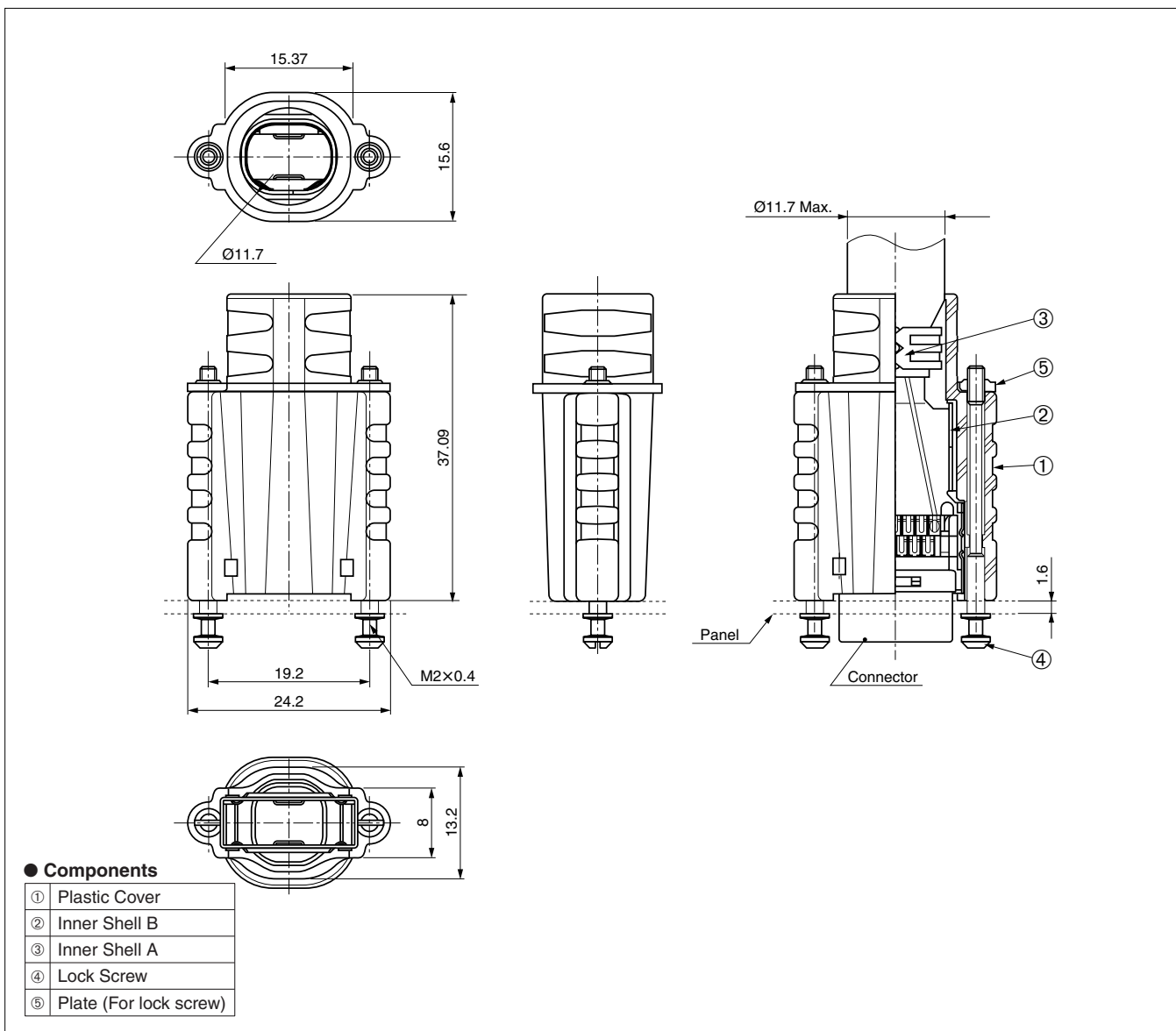

Mating connector: HDR series of spring-lock type connector

For use with connectors: HDR series of soldering type male or female connector

HDR series of IDC type male or female connector

**EMI-filtered screw-lock vertical type plastic housing
for heavy wires
HDR-E26LPK+**

Housing

Vertical type

EMI-filtered countermeasures

RoHS



● Configuration of product Part No.

HDR- E 26 LP K+

① ② ③ ④

- ① Series name
 - ② No. of contacts: 26
 - ③ Form of housing
Vertical type housing
 - ④ Serial number
- For use with cables: Outside diameter of cable: 10.0-11.7 mm

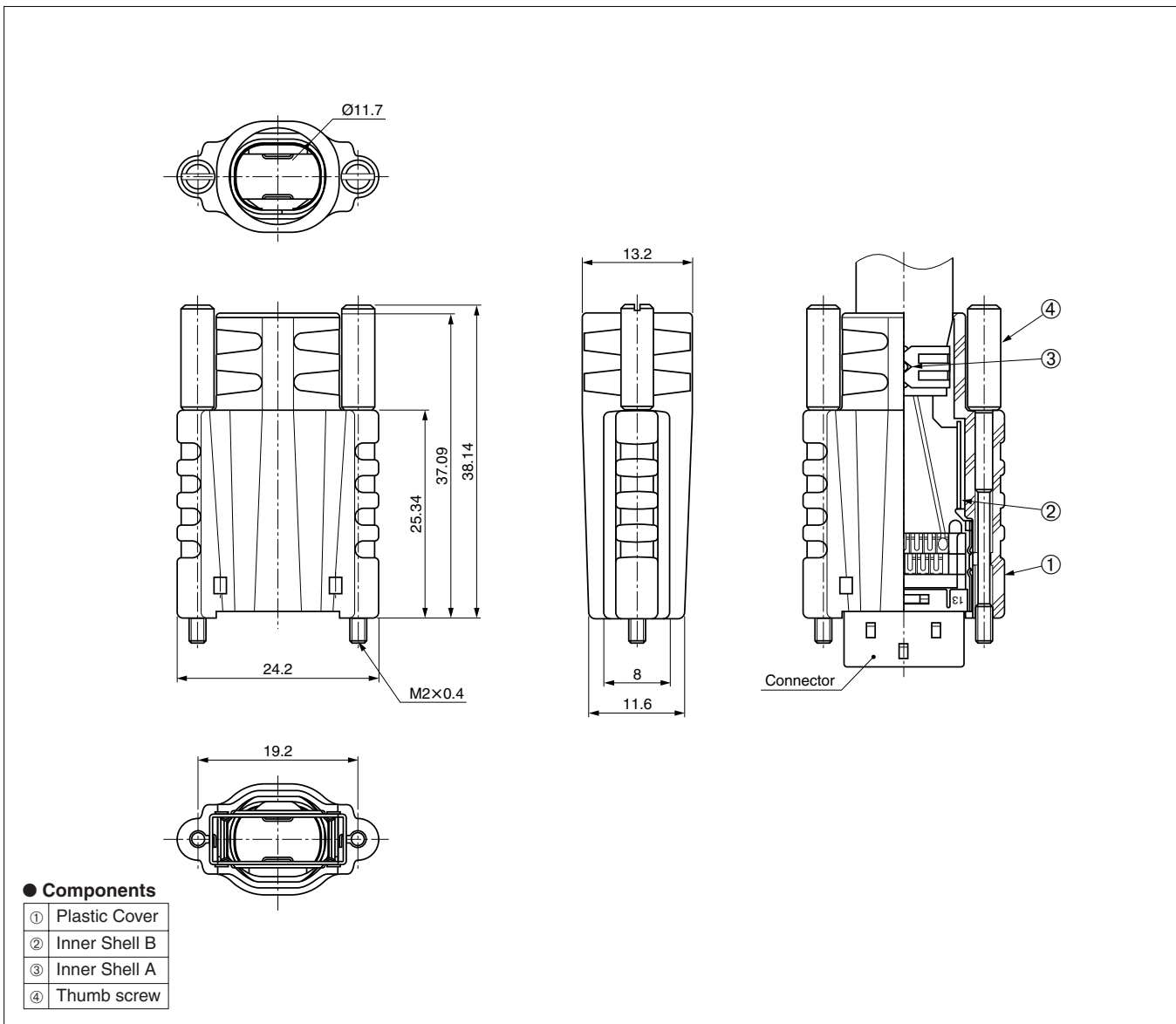

Mating connector: HDR series of screw-lock type connector

For use with connectors: HDR series of soldering type male or female connector

HDR series of IDC type male or female connector

EMI-filtered spring-lock vertical type plastic housing
HDR-E26LPJ+

Housing

Vertical type

EMI-filtered countermeasures

RoHS



● Configuration of product Part No.

HDR- E 26 LP J+

① ② ③ ④

- ① Series name
- ② No. of contacts: 26
- ③ Form of housing
Vertical type housing
- ④ Serial number

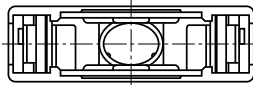
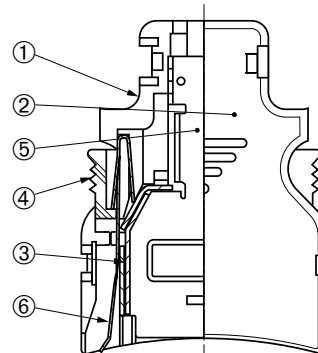
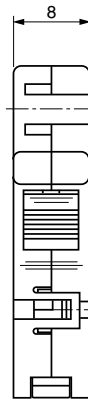
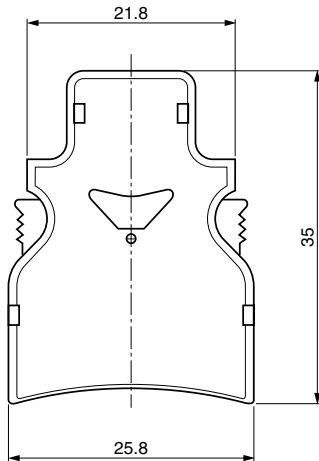
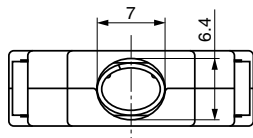

● Components

①	Plastic Cover A
②	Plastic Cover B
③	Inner Shell B
④	Button
⑤	Inner Shell A
⑥	Lock spring

Mating connector: HDR series of spring-lock type connector

For use with connectors: HDR series of soldering type male or female connector

HDR series of IDC type male or female connector

EMI-filtered vertical type plastic housing with mounting hardware for spring-lock, for thin wires and relay connections
HDR-E26LPHA+

Housing

For Relay connections

RoHS

EMI-filtered countermeasures



● Configuration of product Part No.

HDR- E 26 LP H A+

① ② ③ ④ ⑤

- ① Series name
- ② No. of contacts: 26
- ③ Form of housing
Vertical type housing
- ④ Serial number
For use with cables: Outside diameter of thin wire: 5.8-6.5 mm
- ⑤ Thickness of relay panel: 1.6 mm

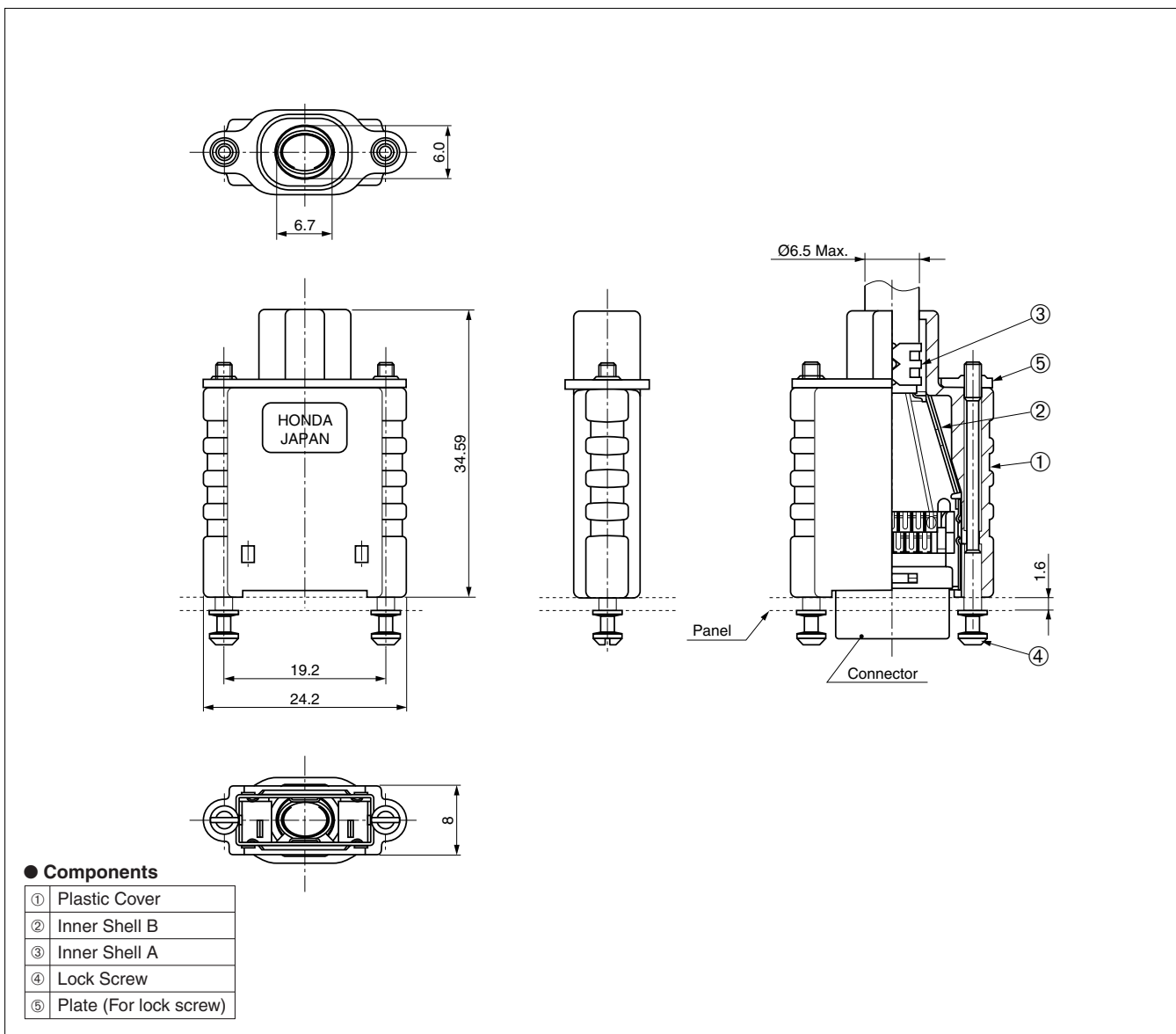

● Components

①	Plastic Cover
②	Inner Shell B
③	Inner Shell A
④	Lock Screw
⑤	Plate (For lock screw)

Mating connector: HDR series of screw-lock type connector

For use with connectors: HDR series of soldering type male or female connector

HDR series of IDC type male or female connector

Soldering type female connector for cables
HDR-E26FSG1+

0.8 mm pitch connector

For cables

Soldering type

RoHS

EMI-filtered countermeasures



● Configuration of product Part No.

HDR- E 26 FS G1+

① ② ③ ④ ⑤

- ① Series name
- ② With metal shell
- ③ No. of contacts: 26
- ④ Form of housing
 FS: Soldering type, female connector, AWG#28
 Insulator OD: 1.0 mm max.
- ⑤ Contact plating
 G1: Min. 0.76 mm Gold plate

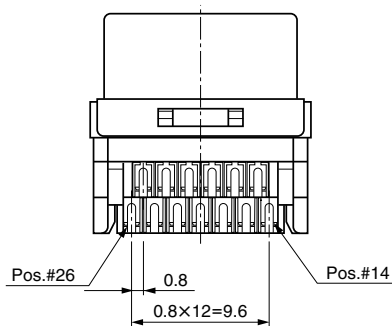
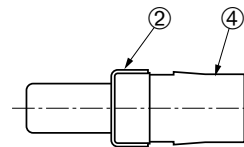
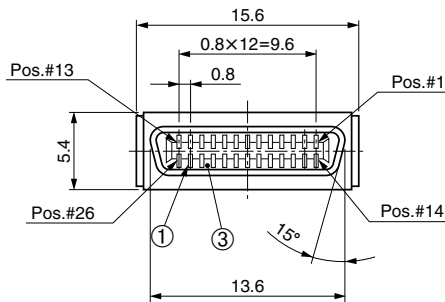
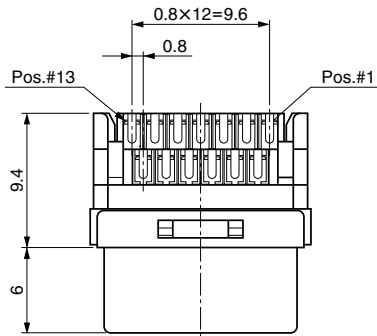

● Components

①	Female Contact
②	Shell
③	Insulator
④	Spacer

Mating connector: HDRA series, male connector

For use with connectors: HDR-E26LPH(), HDR-E26LPJ+, HDR-E26LPK(), HDR-E26ALP()+

EMI-filtered screw-lock right-angle type plastic housing HDR-E26ALPA+

0.8 mm pitch connector

Housing

Right-angle

EMI-filtered countermeasures

RoHS



● Configuration of product Part No.

HDR- E 26 ALP A+

① ② ③ ④

- ① Series name
- ② No. of contacts: 26
- ③ Form of housing
Right-angle
- ④ Serial number
For use with cables: Outside diameter of cable: 6.2-6.8 mm

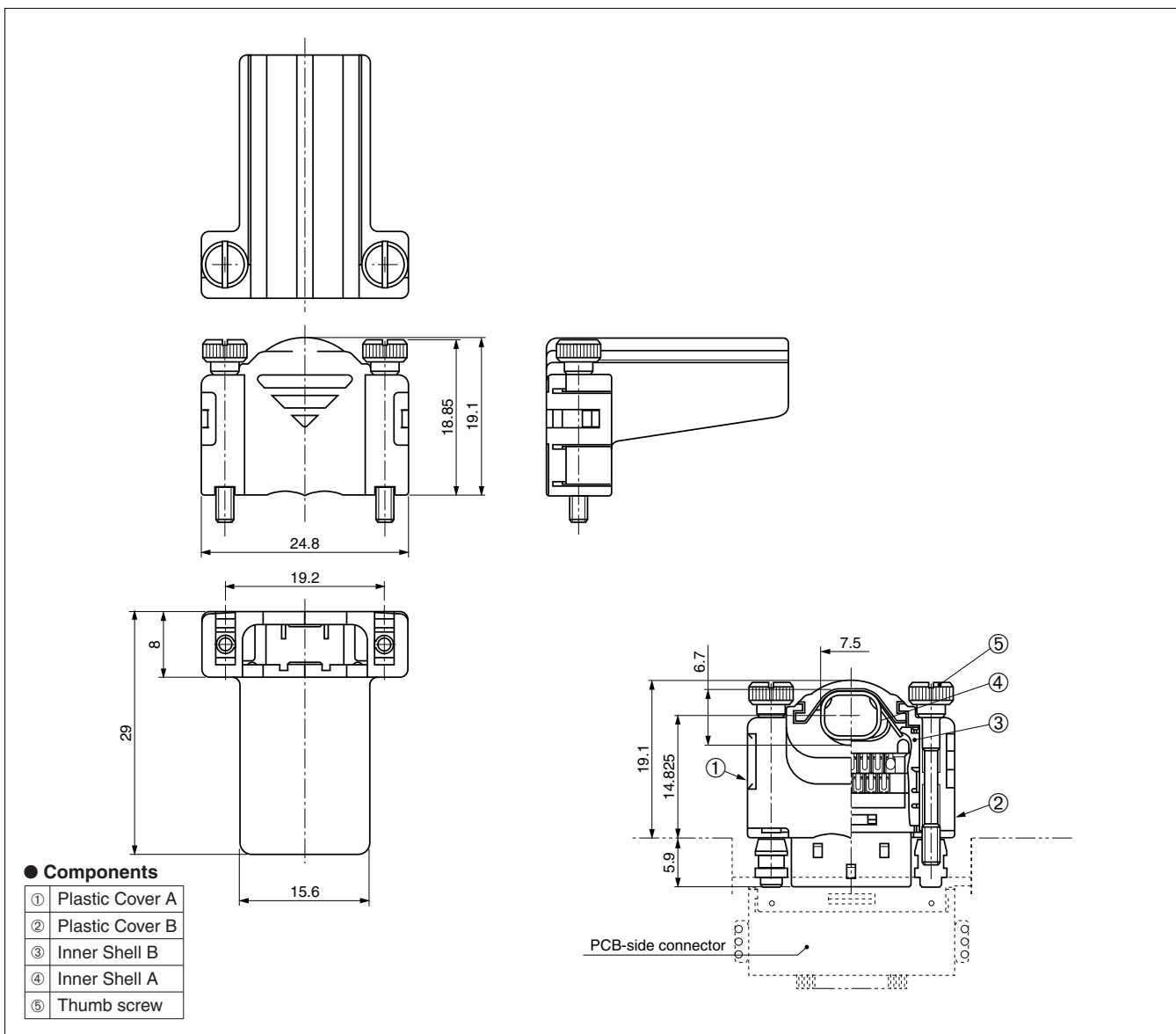

Mating connector: HDR series of screw-lock type connector

For use with connectors: HDR series of soldering type male or female connector

HDR series of IDC type male or female connector

**EMI-filtered screw-lock vertical type plastic housing
HDR-E50LPH**

0.8 mm pitch connector

Housing

Vertical type

EMI-filtered countermeasures

RoHS



● Configuration of product Part No.

HDR- E 50 LP H

① ② ③ ④

- ① Series name
- ② No. of contacts: 50
- ③ Form of housing
Vertical type housing
- ④ Serial number

Technical drawings showing dimensions and components:

- Top view: Ø9
- Side view: 0.8, 33.8, 3, M2×0.4, 25.34, 34.59, 38.14
- Front view: 8, 10
- Bottom view: 28.8
- Cross-sectional view: ①, ②, ③, ④

Connector
HDR-E50MSG1+

● Components

①	Plastic Cover
②	Inner Shell B
③	Inner Shell A
④	Thumb screw

Mating connector: HDR series of screw lock type connectors

For use with connectors: HDR-E50MSG1+

HDR-E50M()G()+